

Magnetic field sensor for pneumatic cylinders BIM-IKE-AD4X-H1141 W/KLI-3

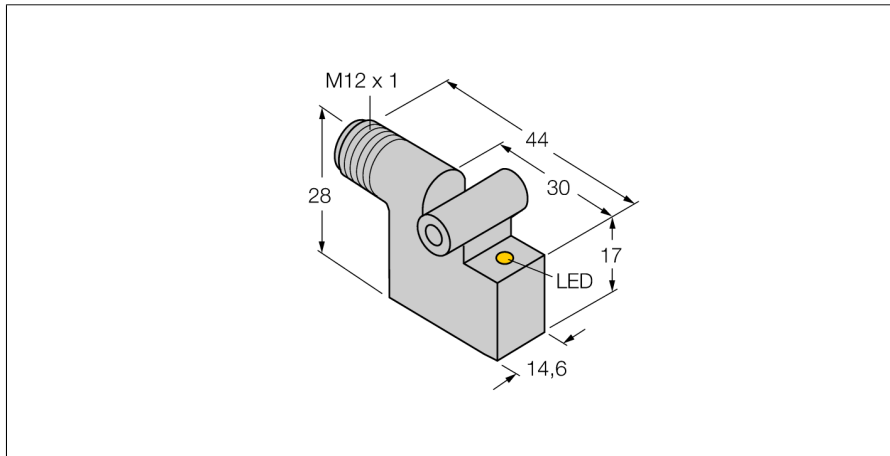

- Rectangular, height 28 mm
- Metal, GD-Zn
- Magnetic-inductive sensor
- DC 2-wire, 10...65 VDC
- NO contact
- Male connector M12 x 1

Wiring Diagram

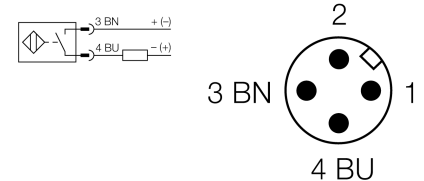

Type designation	BIM-IKE-AD4X-H1141 W/KLI-3
Ident-No.	4421690
Ident-No (TUSA)	S4421690
Pass speed	≤ 3 m/s
Repeatability	≥ ± 0.1 mm
Temperature drift	≤ 0.1 mm
Hysteresis	≤ 1 mm
Ambient temperature	-25...+70 °C
Operating voltage	10...65 VDC
Residual ripple	≤ 10 % U _s
DC rated operational current	≤ 100 mA
Residual current	≤ 0.8 mA
Isolation test voltage	≤ 0.5 kV
Short-circuit protection	yes/ Cyclic
Voltage drop at I _s	≤ 4 V
Wire breakage/Reverse polarity protection	no/ Complete
Switching frequency	0.3 kHz
Design	Rectangular, IKE
Dimensions	30 x 14.6 x 28 mm
Housing material	Metal, GD-Zn
Active area material	Plastic, PA12-GF30
Electrical connection	Connector, M12 x 1
Vibration resistance	55 Hz (1 mm)
Shock resistance	30 g (11 ms)
Protection class	IP67
MTTF	2283 years acc. to SN 29500 (Ed. 99) 40 °C
Mounting on the following profiles	○ □ ○
Cylindrical design	○ □ ○
Switching state	LED yellow
Included in delivery	KLI3

Functional principle

Magnetic field sensors are activated by magnetic fields and are especially suited for piston position detection in pneumatic cylinders. Based on the fact that magnetic fields can permeate non-magnetizable metals, it is possible to detect a permanent magnet attached to the piston through the aluminium wall of the cylinder.

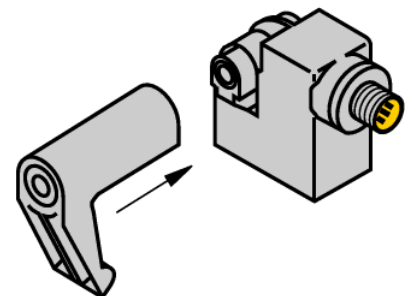
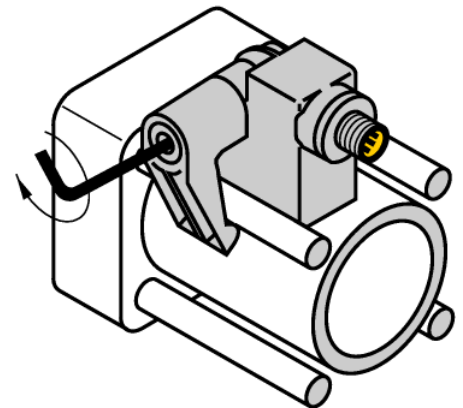

**Magnetic field sensor
for pneumatic cylinders
BIM-IKE-AD4X-H1141 W/KLI-3**

Mounting instructions/Description

Active face in front



**Magnetic field sensor
for pneumatic cylinders
BIM-IKE-AD4X-H1141 W/KLI-3**





Accessories

Type code	Ident-No.	Description	
KLF-5Z	6971803	Mounting on tie-rod cylinders; cylinder diameter 32...63 mm; material: Aluminum	
KLI-6Z	6971806	Mounting on tie-rod cylinders; cylinder diameter 50...125 mm; material: Aluminum	
KLI-6	6971805	Mounting on profile cylinder; cylinder diameter 50...100 mm; material: Aluminum	
KLI7	6971810	Mounting on profile cylinder with external dovetail grooves; diameter 32...200 mm; material: Aluminium	
KLF-3	69710	Mounting on tie-rod cylinders; cylinder diameter 32...100 mm; material: Die-cast zinc	

**Magnetic field sensor
for pneumatic cylinders
BIM-IKE-AD4X-H1141 W/KLI-3**

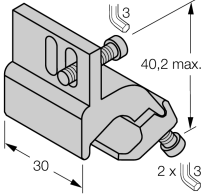

Accessories

Type code	Ident-No.	Description	
KLF-5	6971802	Mounting on  profile cylinder; cylinder diameter 32...50 mm; material: Aluminium	
KLF-4	69712	Mounting on  tie-rod cylinders; cylinder diameter 63...160 mm; material: Die-cast zinc	