

piconet® extension module for IP-Link
4 analog inputs 0(4)... 20 mA
SNNE-40A-0007

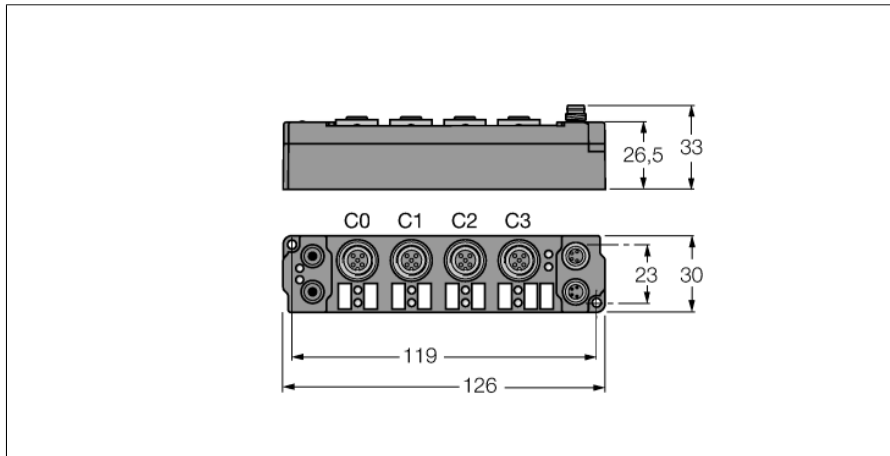

- 4 analogue inputs 0(4)...20 mA
- Direct connection to the IP link
- Fibre-glass reinforced housing
- Encapsulated module electronics
- Metal connector
- Degree of protection IP67

Wejście M12 x 1

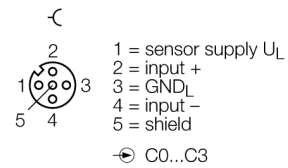

Podłączenie - wejścia

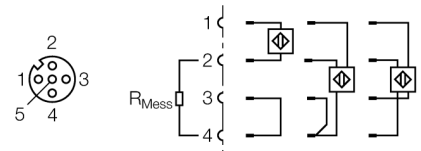

Napięcie zasilania M8 x 1

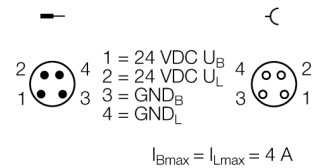

Typ	SNNE-40A-0007
Nr kat.	6824217
Liczba kanałów	4
Napięcie pracy / obciążenia	20...29 VDC
Prąd pracy	≤ 55 mA
Fibre-optic length	≤ 15 m
Liczba kanałów	4 analogue inputs 20 mA
Rezystancja wejścia	80 Ω
Izolacja elektryczna	channels to operational voltage
Common mode voltage	max. 35 V
Mierzony prąd	0.5 mA
Conversion time	250 ms
Relative measuring error	< +/- 0.3 % of full scale
Input filter	variable
Zasilanie czujników	from load voltage
Dimensions (W x L x H)	30 x 126 x 26.5mm
Temperatura pracy	0...+55 °C
Temperatura składowania	-25 to 85 °C
Test wibracyjny	as per EN 60068-2-6
Test przeciążeniowy/wstrząsowy	acc. to DIN EN 60068-2-27
Kompatybilność elektromagnetyczna	according to EN 61000-6-2/EN 61000-6-4
Klasa ochrony	IP67
Certyfikaty	CE, cULus

piconet® extension module for IP-Link
4 analog inputs 0(4)... 20 mA
SNNE-40A-0007

LEDs

	LED designation	Status green	Status red	Function
IP-Link / module status	RUN / ERR (I/O)	flickers/ON	OFF	Receiving error-free IP-Link protocols
		flickers	flickers	Receiving faulty IP-Link protocols
		OFF	flickers	Receiving faulty IP-Link protocols / system fault
		OFF	ON	No receipt of IP-Link protocols / module error
Inputs	R / E (1...4)	OFF		No data transmission
		ON		Data transmission to D/A converter
			OFF	Error-free data transmission
			ON	Wire break, measured value out of measuring range, etc.
Power supply	U _B	OFF		Operating voltage U _B < 18 VDC
		ON		Operating voltage U _B ≥ 18 VDC
	U _L	OFF		Load voltage U _L < 18 VDC
		ON		Load voltage U _L ≥ 18 VDC

Dane z odwzorowania procesu

Valid for the setting "Motorola format"

SBn: Status byte channel n
 CBn: Control byte channel n
 Chn D0: channel n,
 least significant data byte
 Chn D1: channel n,
 most significant data byte

Pre-conditions	Address	Input data		Output data	
	Word	High-Byte	Low-Byte	High-Byte	Low-Byte
Compact mapping: Starting with Ch0 D1 in "Low-Byte" word 0 all other bytes follow immediately. Only the user data are mapped (greyed in the table). Complex mapping: Data are mapped with control and status byte.	0	Ch0 D1	SB0	Ch0 D1	CB0
	1	SB1	Ch0 D0	CB1	Ch0 D0
	2	Ch1 D0	Ch1 D1	Ch1 D0	Ch1 D1
	3	Ch2 D1	SB2	Ch2 D1	CB2
	4	SB3	Ch2 D0	CB3	Ch2 D0
	5	Ch3 D0	Ch3 D1	Ch3 D0	Ch3 D1